

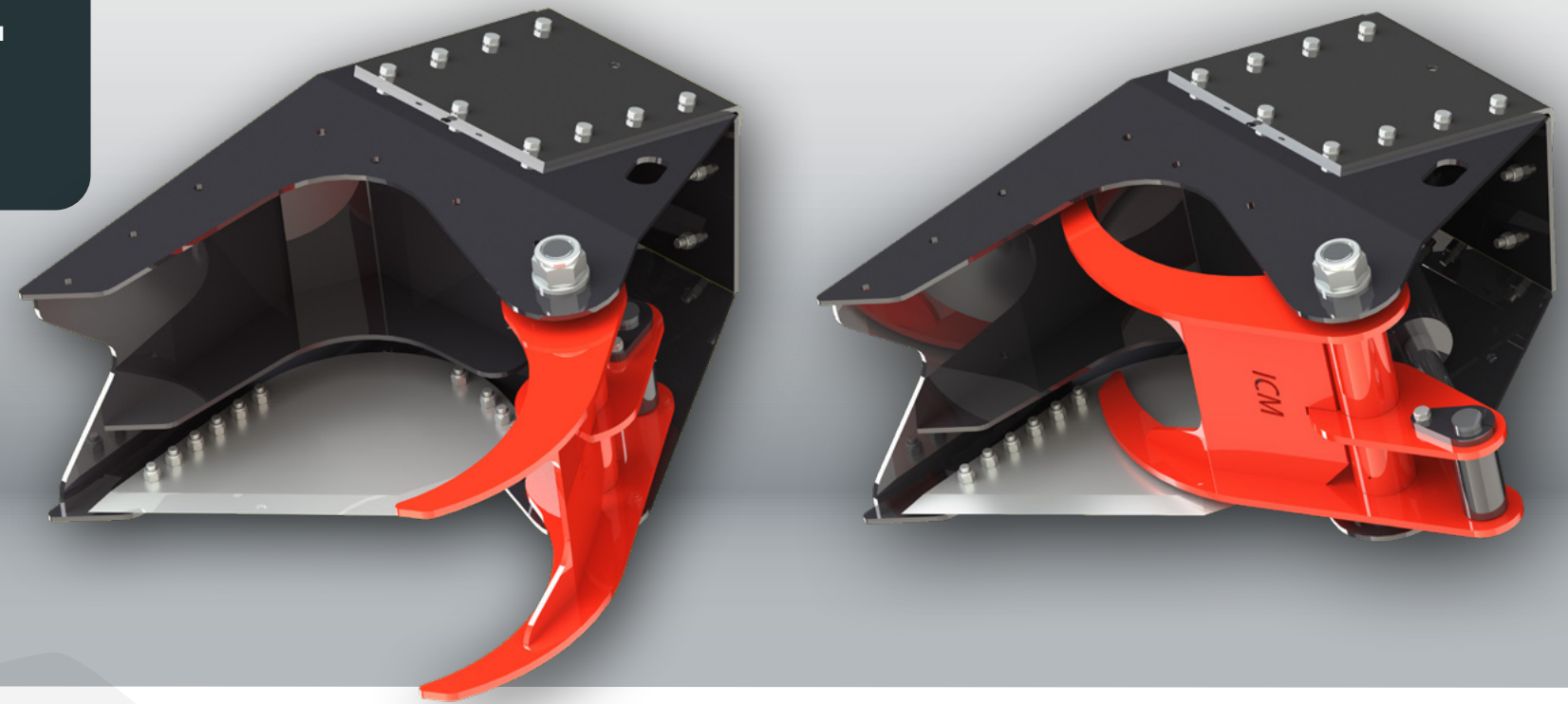

COMPATIBLE WITH



EXCAVATORS



TREE SHEAR GRA-C

FOR PRECISE AND FAST CUTTING AND
REMOVAL OF LOGS AND SHRUBS

FIXED BLADE

- Developed to work at higher pressures, ensuring strength and cutting speed
- Hardox400 blade for extra durability
- Including flat plate to manufacture quick hitch
- Rotation with slew ring available as optional

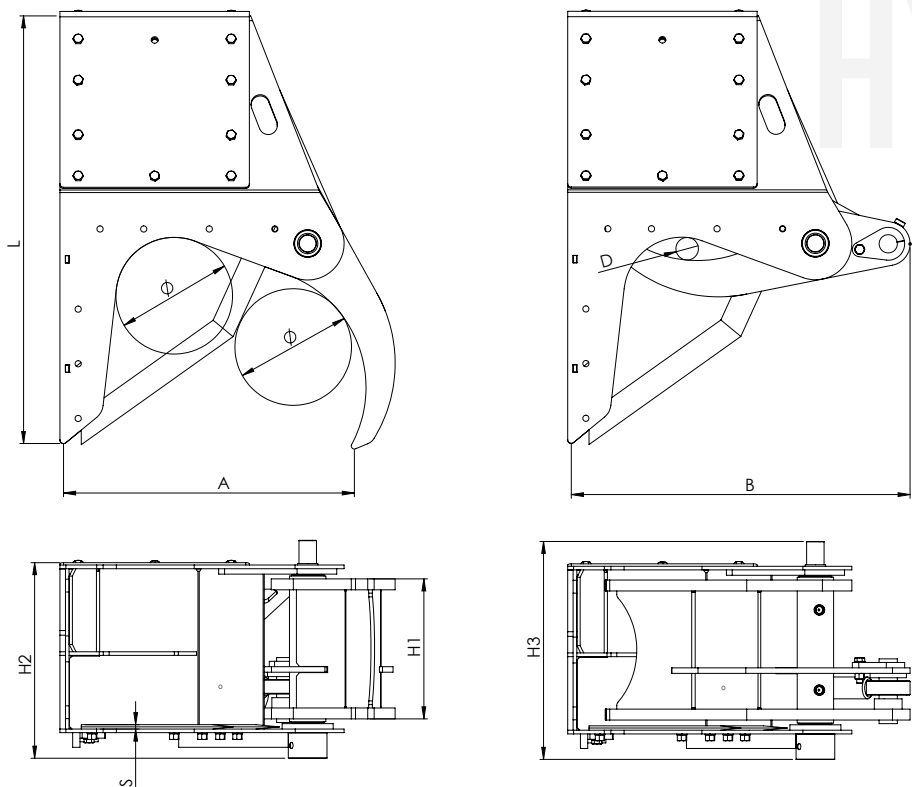

EXCAVATORS	TON	2-5	5-15	15-30
MODEL		GRA-C 20	GRA-C 30	GRA-C 45
WEIGHT	kg	114	360	980
MAX PRESSURE	bar	250	250	250
MAX FLOW RATE	lt/min	35	60	120
CUTTING FORCE	daN	8800	18250	27000
Ø - MAX CUTTING DIAMETER	mm	227	335	504
D - MINIMUM DIAMETER	mm	13	33	74
A	mm	613	810	1245
B	mm	638	939	1479
L	mm	822	1186	1743
H1	mm	184	354	484
H2	mm	400	510	640
H3	mm	431	568	710
S - BLADE THICKNESS	mm	12	12	20

OPTIONAL



ROTATION

MAX PRESSURE	bar	250	250	250
MAX FLOW RATE	lt/min	30	30	30



EXCAVATOR COUPLING